

SMH110D-0120 Servo Motor

FEATURES

- 24-70VDC
- 1260W Power Rating
- Rated Torque of 4 Nm
- Maximum Speed of 4000 RPM
- Rated Speed of 3000 RPM
- 2500 PPR Incremental Encoder
- IP65 for Body, IP54 Shaft Seal
- Insulation Class F
- Brake Option Available
- CE Certified



DESCRIPTION

The SMH110D-0120 Series Servo Motor offers a low-cost solution for motion control applications requiring position and speed control. With the 2500 PPR Incremental Encoder it allows for better cushioning ability and higher cost-performance ratio. These Servo Motors have Insulation Class F which is the best Insulation Class on the market. They are very quiet with high reliability and stability in high temperature environments. These Servo Motors boast peak torque values up to 12 Nm, provide excellent dynamic response, allow for 3 times the overload capacity, and has a rated torque of 4 Nm. It is available in a 110mm square flange size, with a brake option.

ORDERING INFORMATION

SMH110D-0120-30AAK - 4DKR

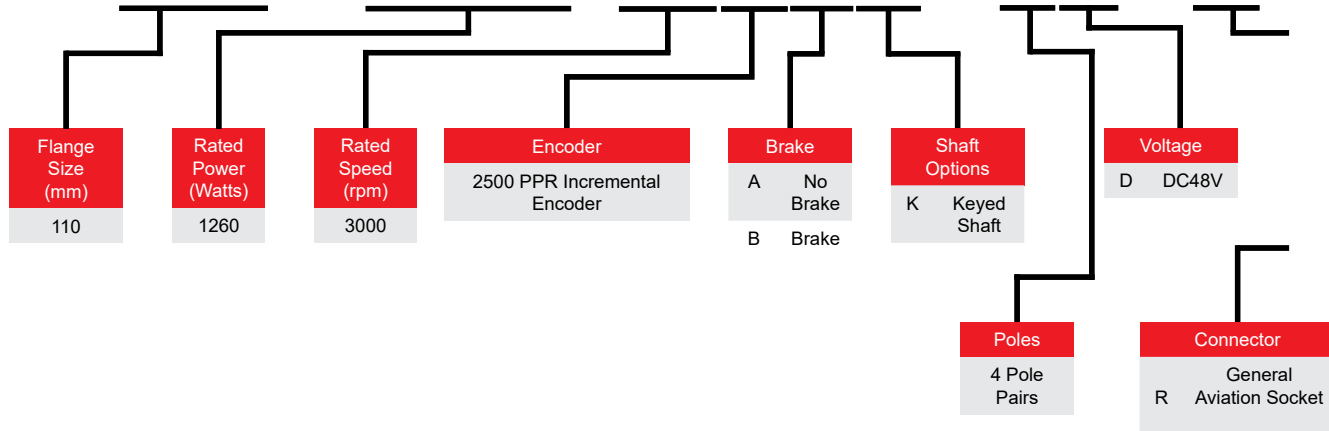

L011822

Model	SMH110D-0120-30AAK-4DKR SMH110D-0120-30ABK-4DKR
Compatible Driver	FD144S-LB-000
DC Link Voltage (VDC)	48
Rated Power (W)	1260
Rated Torque (Nm)	4
Rated Speed (RPM)	3000
Max Speed (RPM)	4000
Rated Current (A)	32
Maximum Torque (Nm)	12
Maximum Current (A)	96
Rated Standstill Torque (Nm)	4.4
Rated Standstill Current (A)	35.2
Resistance Line-Line (Ω)	0.035
Inductance Line-Line (mH)	0.2
Electrical Time Constant (ms)	5.7
Mechanical Time Constant (ms)	2 2.1 (with brake)
Torque Constant Kt (Nm/A)	0.132
Rotor Moment of Inertia Jm (Kg-cm ²)	5.8 6.1 (with brake)
Brake Holding Torque (Nm)	10
Pole Pair Number	4
Maximum Voltage Rising du/dt (KV/ μ s)	8
Insulation Class	F
Maximum Radial Force F (N)	630
Maximum Axial Force F (N)	315
Weight (Kg)	6.2 7.2 (with brake)
Length of Motor (mm)	168 \pm 1.5 228 \pm 1.5 (with brake)

SMH110D-0120-30AAK-4DKR

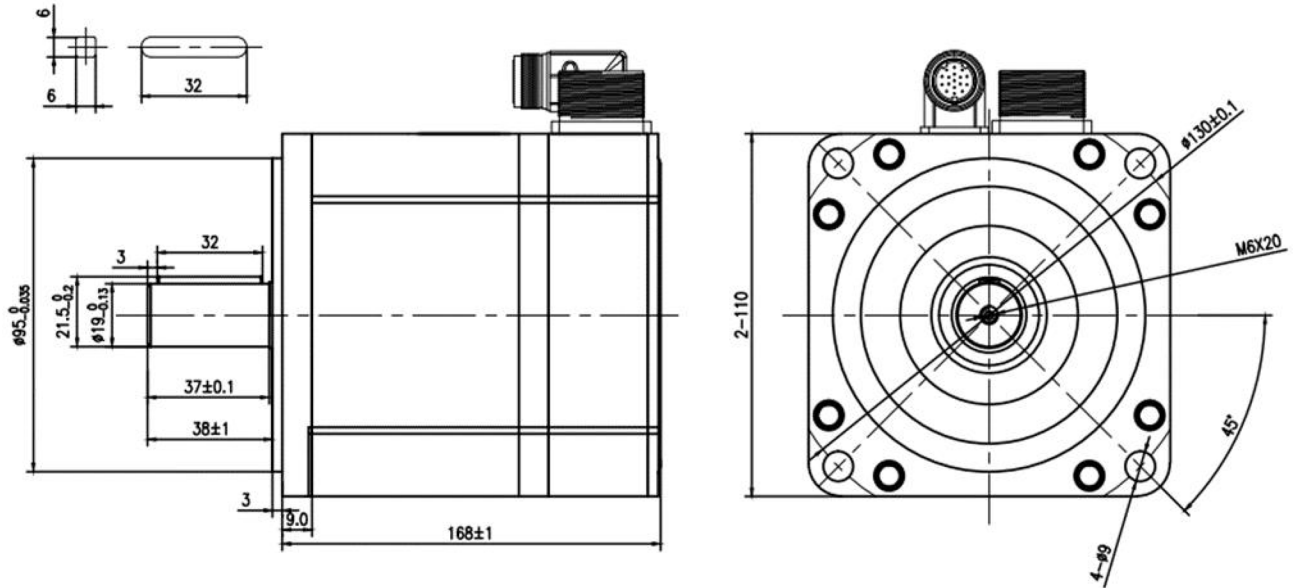

Model	SMH110D-0120-30AAK-4DKR SMH110D-0120-30ABK-4DKR
-------	--

Length of Motor
L (mm)

168 ± 1.5
228 ± 1.5 (with brake)

Dimensions are in mm

SMH110D-0120-30ABK-4DKR

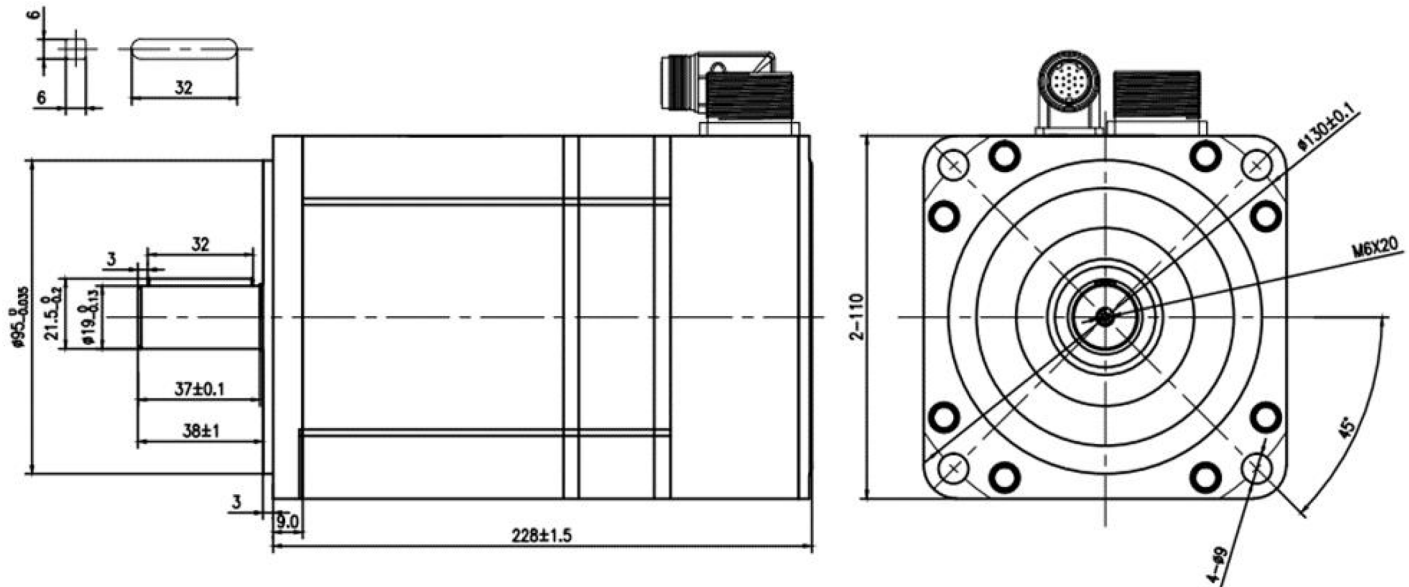

DIMENSIONS

TORQUE CURVE

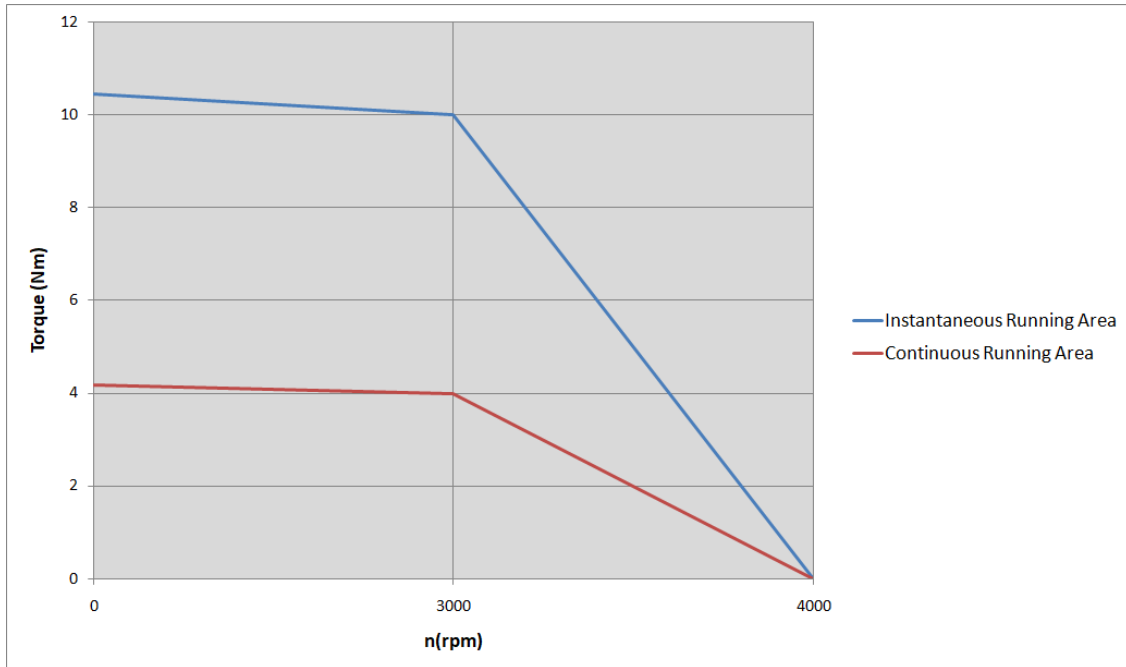

Motor Cable: MOT-040-05-KC5 for SMH110D-0120-30AAK-4DKR

WIRING PINOUTS

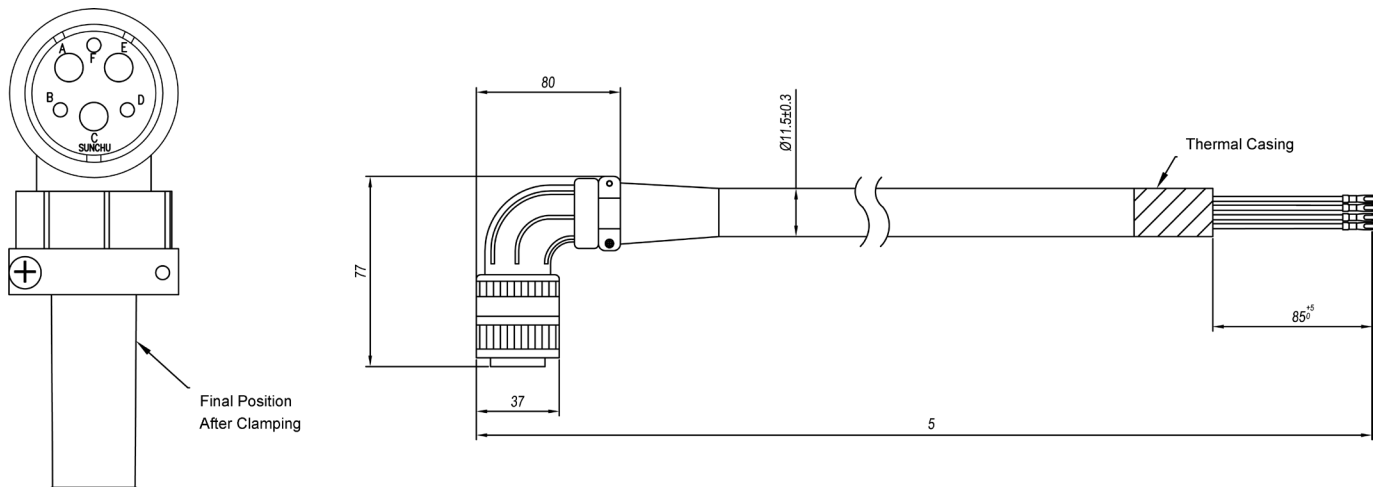

MOT-040-05-KC5		
Cable Color	Signal	PIN #
Yellow	U	PINA
Red	V	PINE
Green	W	PINC
Yellow-green	PE	PINF
Shield	Shield	Metal Ring

Motor Cable with Brake Cable: MOT-040-05-KC5-B for SMH110D-0120-30ABK-4DKR

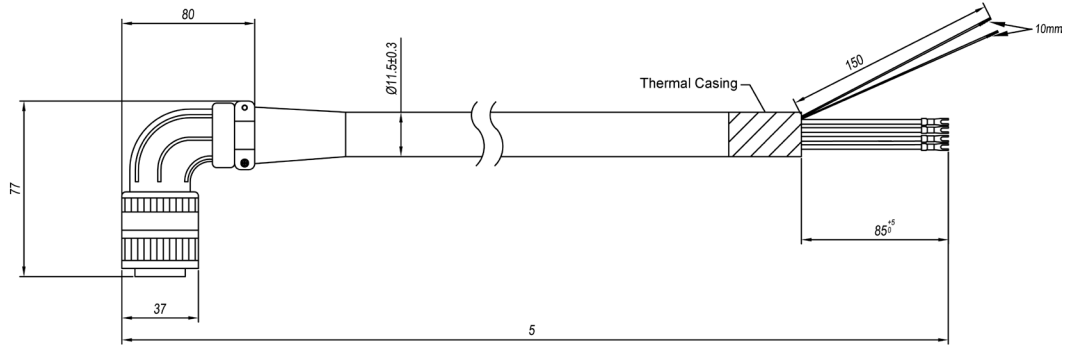
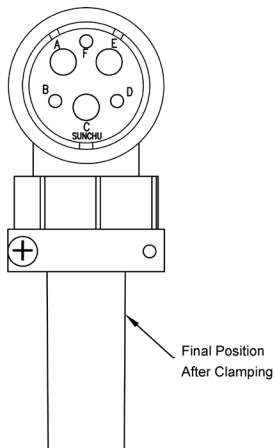

MOT-040-05-KC5-B		
Cable Color	Signal	Pin #
Yellow	U	PINA
Red	V	PINE
Green	W	PINC
Yellow/Green	PE	PINF
Red	Brake+	PINB
Blue	Brake-	PIND
Shield	Shield	Shield

Encoder Cable: ENCHA-05-KC0 for SMH110D-0120-30AAK-4DKR and SMH110D-0120-30ABK-4DKR

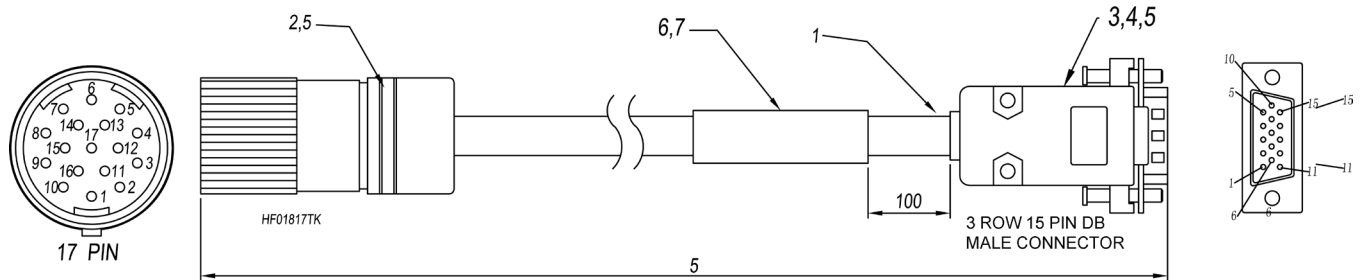

WIRING PINOUTS

ENCHA-05-KC0			
17 PIN Connector	3 Row 15 PIN DB	Signal	Color
PIN1	PIN1	+5V	Red
PIN3	PIN8	A	Orange
PIN5	PIN7	B	Yellow
PIN14	PIN6	Z	Green
PIN9	PIN4	U	Brown
PIN11	PIN10	V	Purple
PIN16	PIN9	W	Blue
PIN2	PIN2	GND	Black
PIN4	PIN13	/A	Orange/White
PIN6	PIN12	/B	Yellow/White
PIN15	PIN11	/Z	Green/White
PIN10	PIN5	/U	Brown/White
PIN12	PIN15	/V	Purple/White
PIN17	PIN14	/W	Blue/White
PIN7	PIN3	PTC/KTY+	Red
PIN8	PIN2	PTC/KTY-	Red/White
Shield			Shield

SPECIFICATIONS

Model	Motor Cable	Encoder Cable	Brake Cable
SMH110D-0120-30AAK-4DKR	MOT-040-05-KC5	ENCHA-05-KC0	N/A
SMH110D-0120-30ABK-4DKR	MOT-040-05-KC5-B		In Motor Cable

Model	SMH110D-0120-30AAK-4DKR SMH110D-0120-30ABK-4DKR	
Length of Motor L(mm)	168 ± 1.5 228 ± 1.5 (with brake)	
Cooling Method	Totally Enclosed, Non-Ventilated	
Protection Level	IP65 for Body, Shaft Sealing IP54	
Environmental Conditions of Operation	Temperature	-20°C~40°C (Non-freezing)
	Humidity	Below 90% RH (Non-condensing)
	Ambient Environment	Away from active gas, combustible gas, oil drops and dust
	Altitude	Maximum Altitude 4000m, Rated Power at 1000m or Below, Above 1000m: Decreasing 1.5% per 100m Rise